

7,8-31,2m	1,2/7,1/13m	5,4t	6,35x6,2m

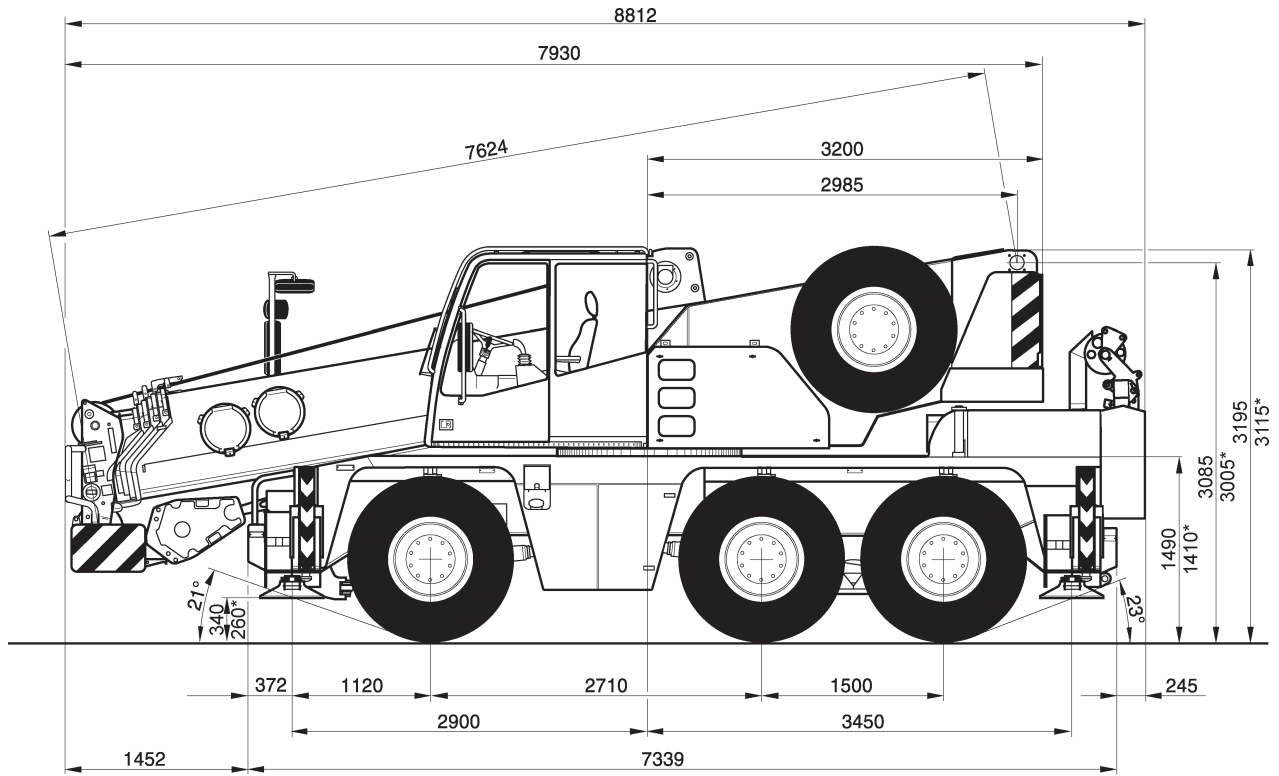

* abgesenkt

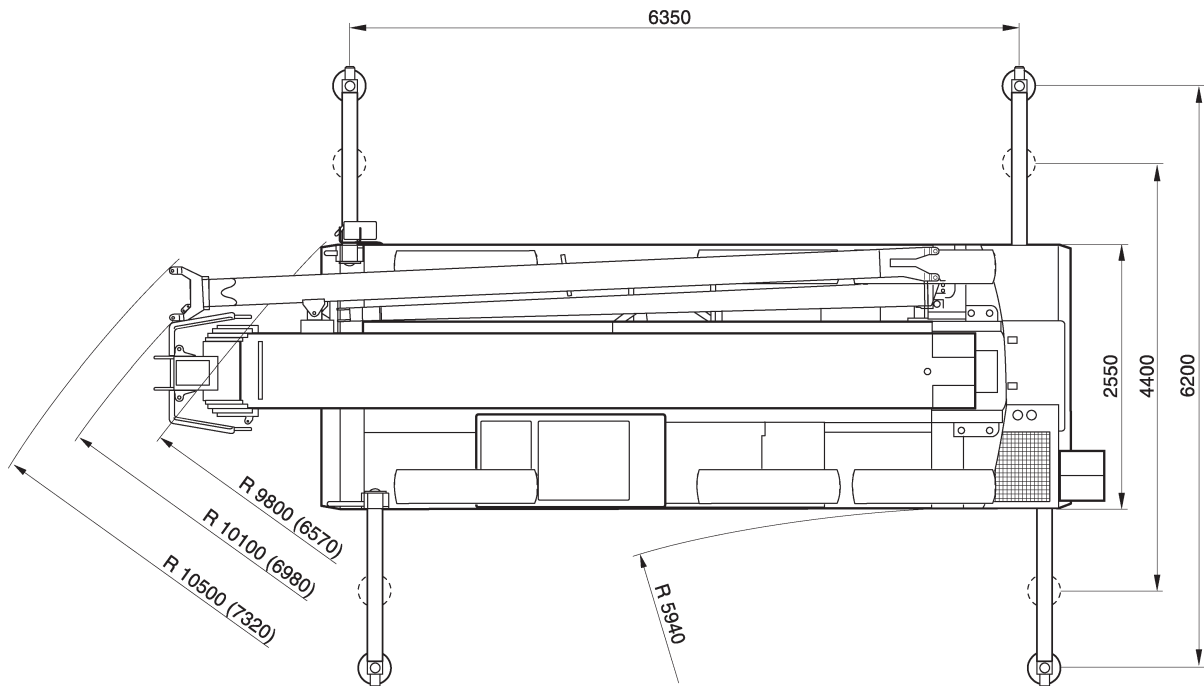

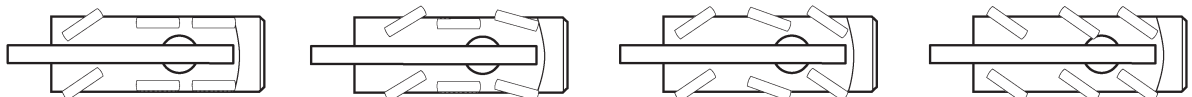



() mit unabhängiger Hinterachslenkung

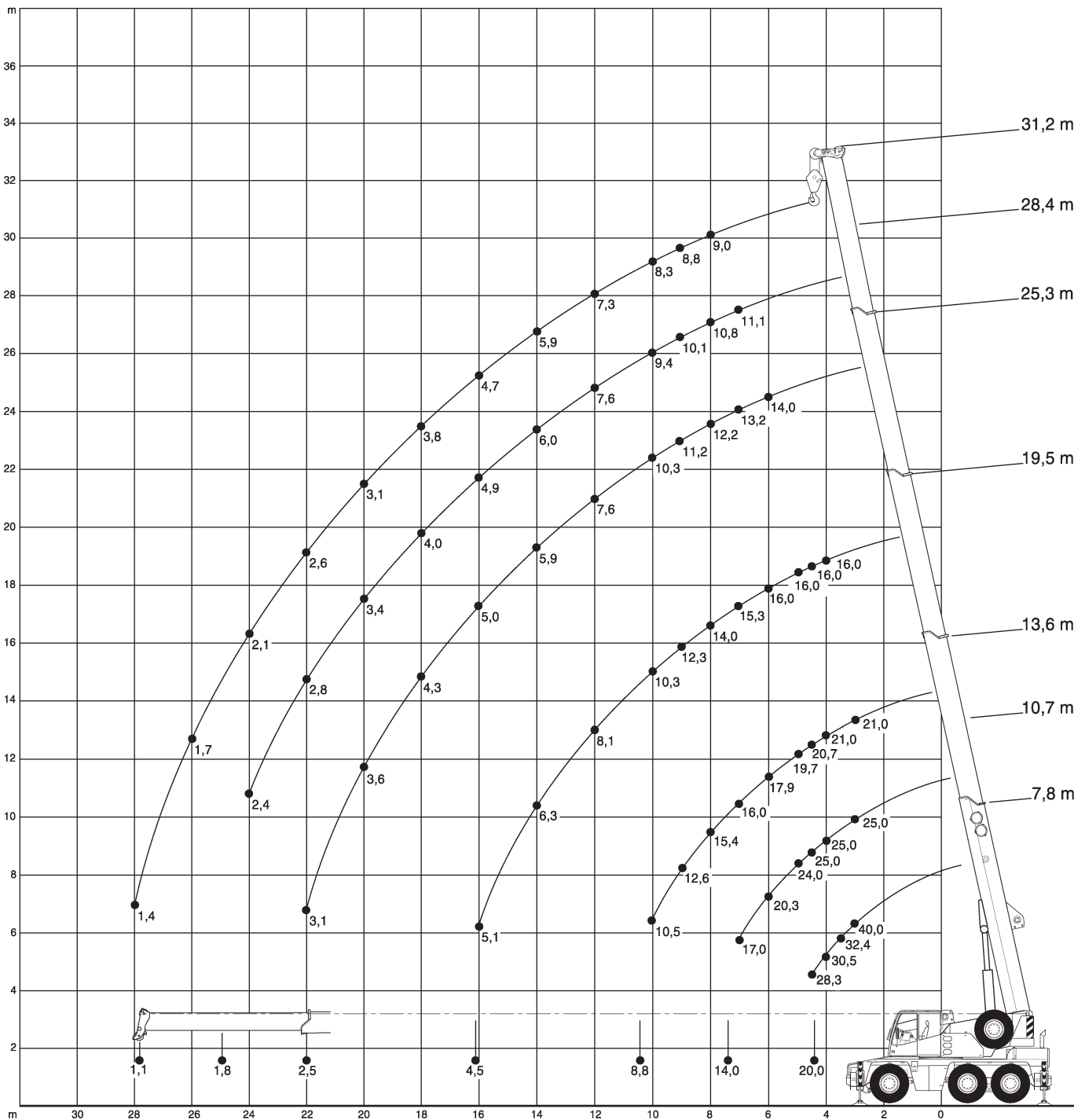

Die Hubhöhen mit Teleskopausleger



Stand 12-2013

				DIN
7,8-31,2m	5,4t	6,35x6,2m	360°	75%

m	7,8	10,7	13,6	19,5	25,3	28,4	31,2	m
3	40*							3
3	34,3	25	21					3
3,5	32,4	25	21					3,5
4	30,5	25	21	16				4
4,5	28,3	25	20,7	16				4,5
5		24	19,7	16				5
6		20,3	17,9	16	14			6
7		17	16	15,3	13,2	11,1		7
8			15,4	14	12,2	10,8	9	8
9			12,6	12,3	11,2	10,1	8,8	9
10			10,5	10,3	10,3	9,4	8,3	10
12				8,1	7,6	7,6	7,3	12
14				6,3	5,9	6	5,9	14
16				5,1	5	4,9	4,7	16
18					4,3	4	3,8	18
20					3,5	3,4	3,1	20
22					3	2,8	2,6	22
24						2,3	2,1	24
26							1,7	26
28							1,4	28

* 0° nach hinten

				DIN
7,8-13,6m	5,4t	freistehend	0°/360°	75%



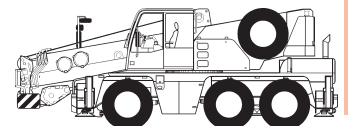

m	7,8		10,7		13,6		m
	0°	360°	0°	360°	0°	360°	
3	14,5		14		15,1		3
3,5	12,9		12,4		13,4		3,5
4	11,5		11,1		12,1		4
4,5	10,4	5,9	10	5,4	11	6,6	4,5
5			9	4,7	10	5,8	5
6			7,5	3,6	8,4	4,7	6
7			6,1	2,8	7,2	3,8	7
8					5,9	3,1	8
9					4,8	2,6	9
10					4,1	2,2	10

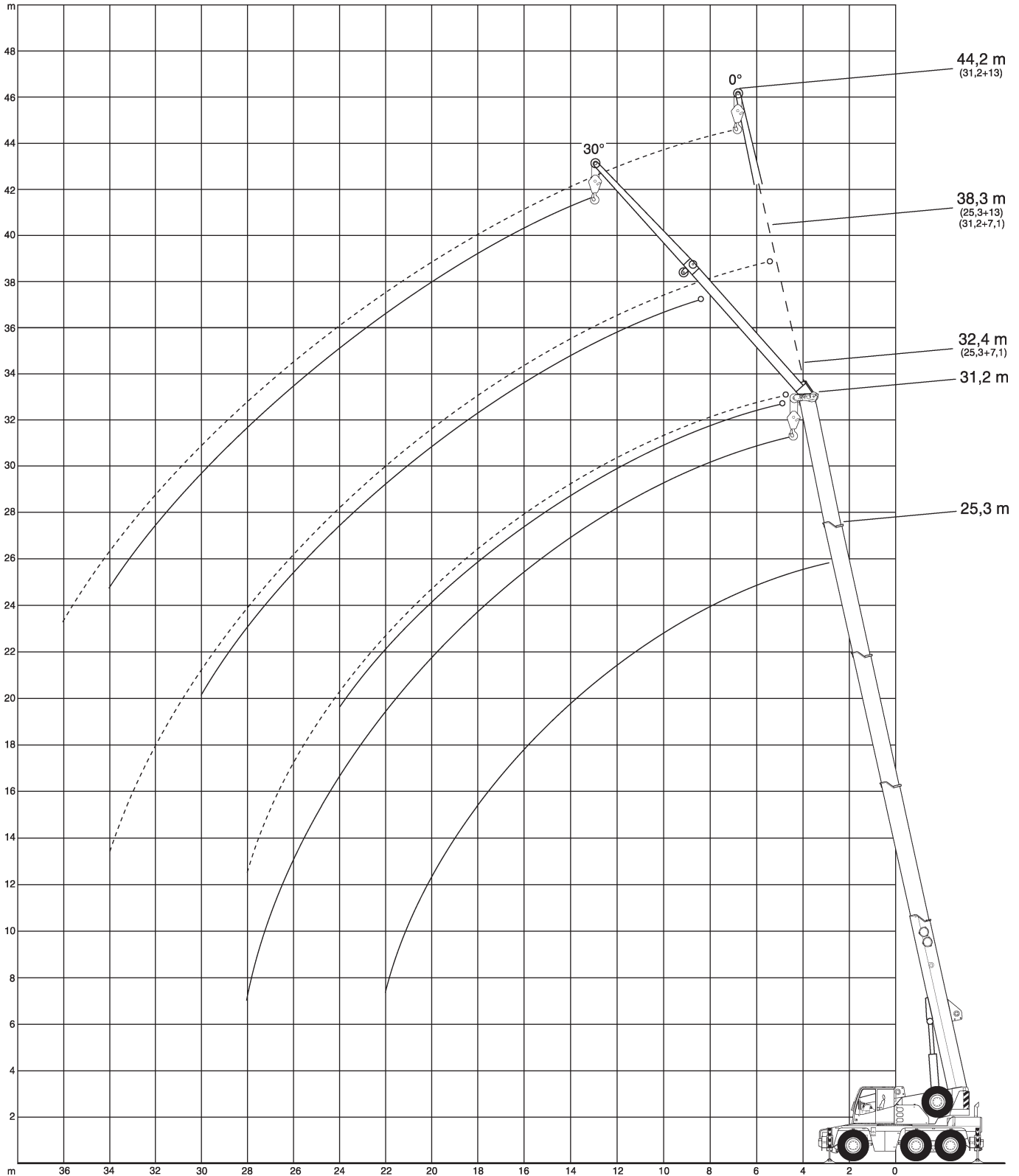





Die Hubhöhen mit Doppelklappspitze



Stand 12-2013

					DIN
25,3-31,2m	7,1m	5,4t	6,35x6,2m	360°	75%

m	25,3		31,2		m
	0°	30°	0°	30°	
8	6,5				8
9	6,2				9
10	5,9	4,2	5		10
12	5,4	4	4,8	3,9	12
14	4,9	3,8	4,6	3,7	14
16	4,5	3,7	4,4	3,5	16
18	4	3,5	4	3,3	18
20	3,3	3,4	3,3	3,1	20
22	2,8	2,9	2,7	2,9	22
24	2,3	2,4	2,2	2,4	24
26	1,9		1,8	2	26
28	1,6		1,5	1,6	28
30			1,2	1,3	30
32			0,9		32
34			0,7		34



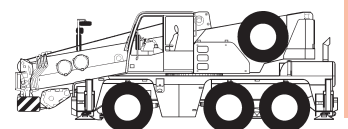

					DIN
25,3-31,2m	13m	5,4t	6,35x6,2m	360°	75%

m	25,3		31,2		m
	0°	30°	0°	30°	
10	3,6				10
12	3,3		3		12
14	3		2,9		14
16	2,8	2,2	2,8		16
18	2,6	2,1	2,7	2,1	18
20	2,4	2	2,5	2	20
22	2,3	1,9	2,4	1,9	22
24	2,1	1,9	2,2	1,9	24
26	2	1,8	1,9	1,8	26
28	1,7	1,8	1,6	1,8	28
30	1,5	1,6	1,3	1,6	30
32	1,2		1,1	1,3	32
34	1		0,9	1	34
36			0,7		36

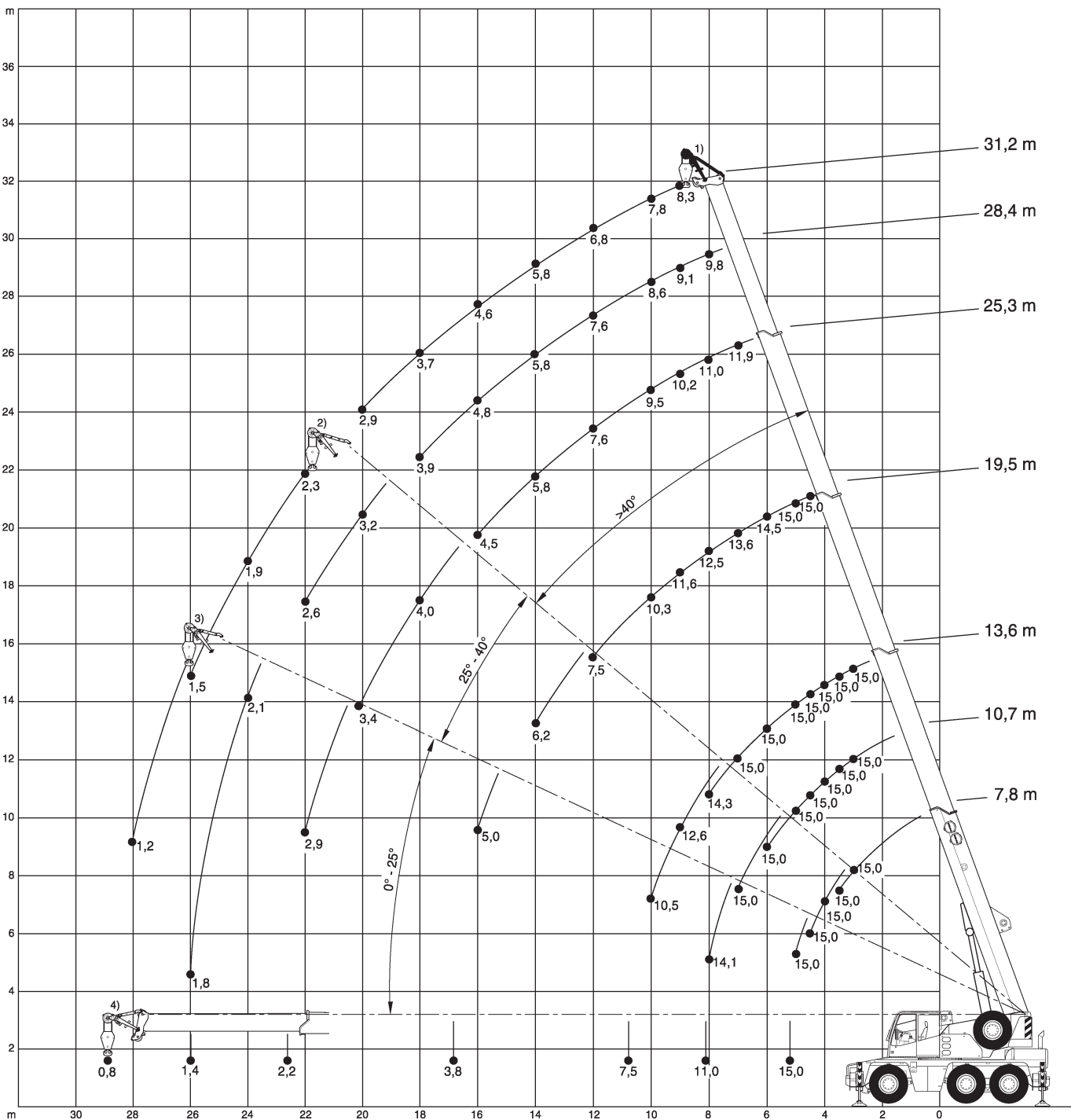

Die Hubhöhen mit Montagespitze



					DIN
7,8-31,2m	1,2m	5,4t	6,35x6,2m	360°	75%

m	7,8*	10,7*	13,6*	19,5*	25,3*	28,4*	31,2*	m
3	15 ¹⁾	15 ¹⁾	15 ¹⁾					3
3,5	15 ¹⁾	15 ¹⁾	15 ¹⁾					3,5
4	15 ²⁾	15 ¹⁾	15 ¹⁾					4
4,5	15 ²⁾	15 ¹⁾	15 ¹⁾	15 ¹⁾				4,5
5	15 ³⁾	15 ¹⁾	15 ¹⁾	15 ¹⁾				5
6		15 ¹⁾	15 ¹⁾	14,5 ¹⁾				6
7		15 ²⁾	15 ¹⁾	13,6 ¹⁾	11,9 ¹⁾			7
8		14,1 ³⁾	14,3 ¹⁾	12,5 ¹⁾	11 ¹⁾	9,8 ¹⁾		8
9			12,6 ²⁾	11,6 ¹⁾	10,2 ¹⁾	9,1 ¹⁾	8,3 ¹⁾	9
10			10,5 ²⁾	10,3 ¹⁾	9,5 ¹⁾	8,6 ¹⁾	7,8 ¹⁾	10
12				7,5 ¹⁾	7,6 ¹⁾	7,6 ¹⁾	6,8 ¹⁾	12
14				6,2 ²⁾	5,8 ¹⁾	5,8 ¹⁾	5,8 ¹⁾	14
16				5 ³⁾	4,5 ¹⁾	4,8 ¹⁾	4,6 ¹⁾	16
18					4 ²⁾	3,9 ¹⁾	3,7 ¹⁾	18
20					3,4 ²⁾	3,2 ²⁾	2,9 ¹⁾	20
22					2,9 ³⁾	2,6 ²⁾	2,3 ²⁾	22
24						2,1 ³⁾	1,9 ²⁾	24
26						1,8 ³⁾	1,5 ²⁾	26
28							1,2 ³⁾	28

* + Montagespitze

1) lange Absteckung

2) mittlere Absteckung

3) kurze Absteckung

Stand 12-2013

